

Auto-mesh & Slab/Wall Design

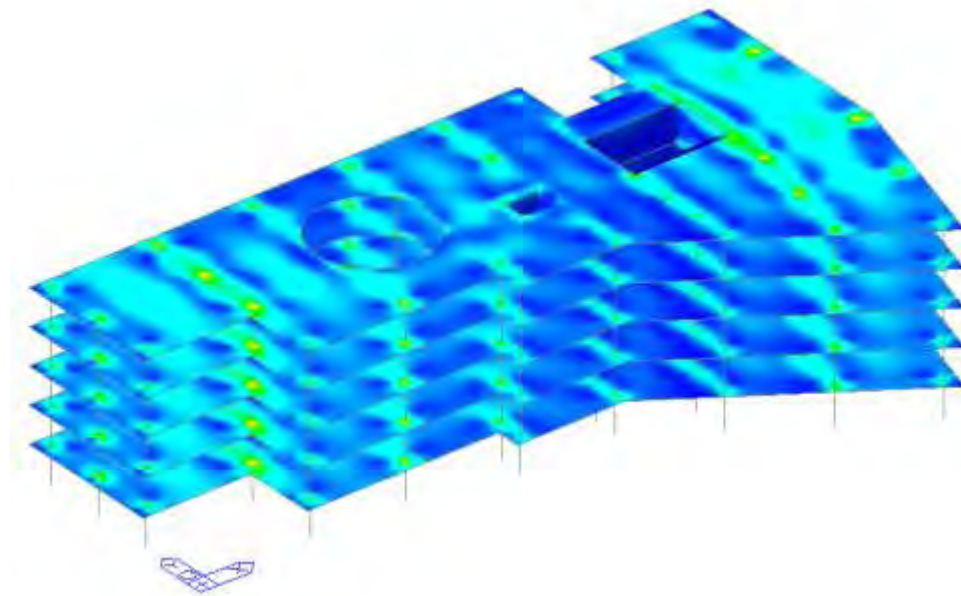

Oct. 09, 2009

Midas Information Technology Co., Ltd.



Contents

1. Summary

Development background

Specification and limitation of automesh feature

2. Main features and applications

Auto-mesh main features

Auto-mesh applications

Slab/Wall Design main features

3. Demonstration

Procedure of Automesh and Slab/Wall Design

4. Further development

Further development items and considerations

01 Summary

Auto-mesh &
Slab/Wall Design

1.2 Development background

❑ Auto-mesh

- A lot of irregular low/middle-rise buildings in Europe need to consider walls and slabs in the analysis model.
- Limitation in Auto-mesh using FX+ when modifying meshes (Re-importing files is required.)

❑ Slab/Wall Design

- Generally one analysis model contains frames, foundations, slabs and walls for design in Europe.
- Difficulties in applying SDS when considering lateral loads as well as gravity loads in slab design

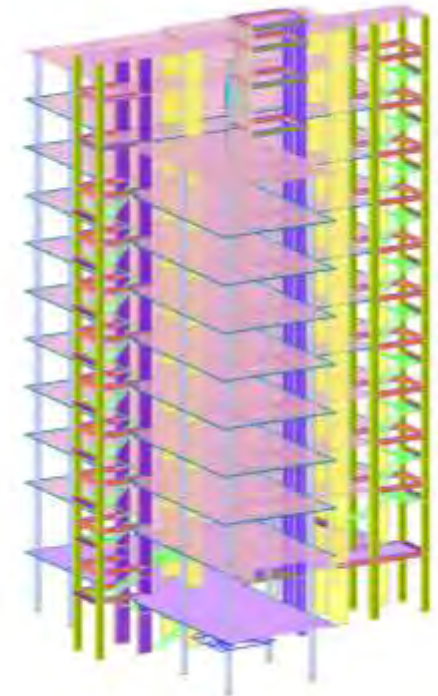
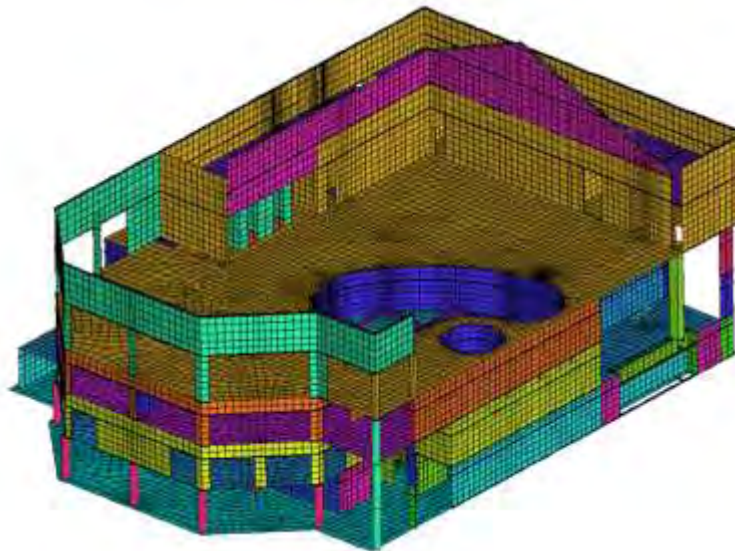
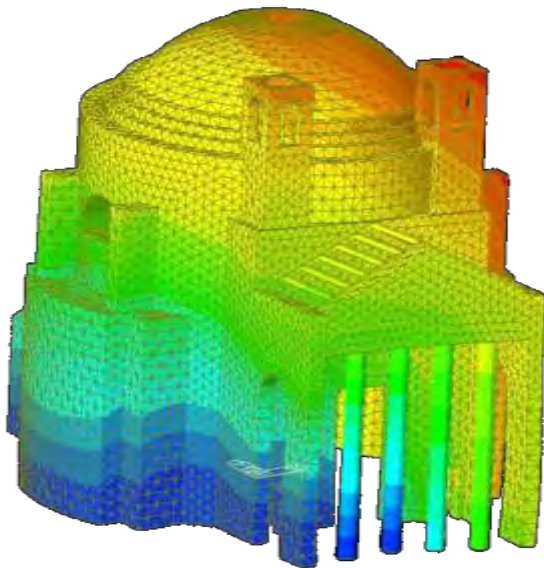

01 Summary

Auto-mesh &
Slab/Wall Design

1.3 Specification and limitation of Auto-mesh features

1) Auto-mesh

- Meshing a plane by selecting areas for wall and slab
- Considering openings
- Auto-consideration of connectivity for Wall, Beam and Column in slab meshes

2) Load

- Static wind and seismic load for flexible floor
- Re-distribution of pressure load when meshing slabs

3) Design

- Wall design feature of meshed wall
- Slab design feature of meshed slab

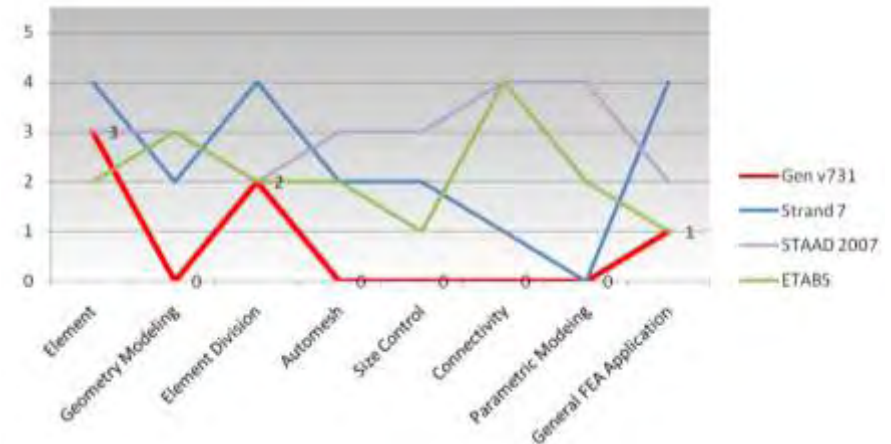

02 Main features and applications

Auto-mesh &
Slab/Wall Design

2.1 Auto-mesh main features

1. Auto-mesh and Map-mesh

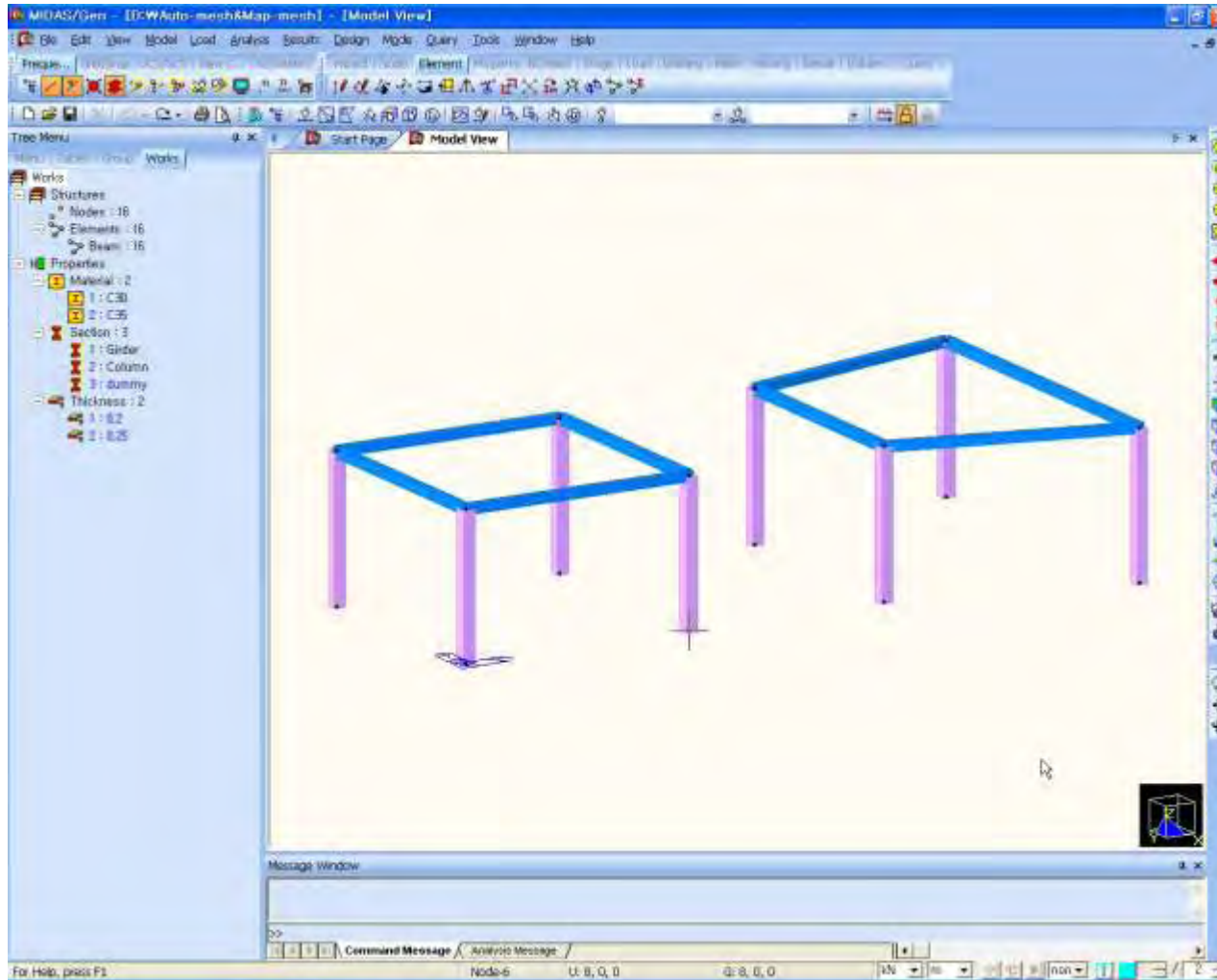

Auto-mesh

- Nodes
- Line Elements
- Planar Elements

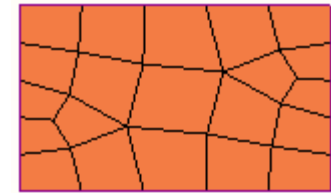

Auto-mesh

Map-mesh

- 4-Node Area

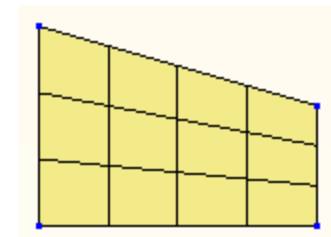

Map-mesh

02 Main features and applications

Auto-mesh &
Slab/Wall Design

2.1 Auto-mesh main features

2. Mesh method (Node, Line Elements, Planar Elements)

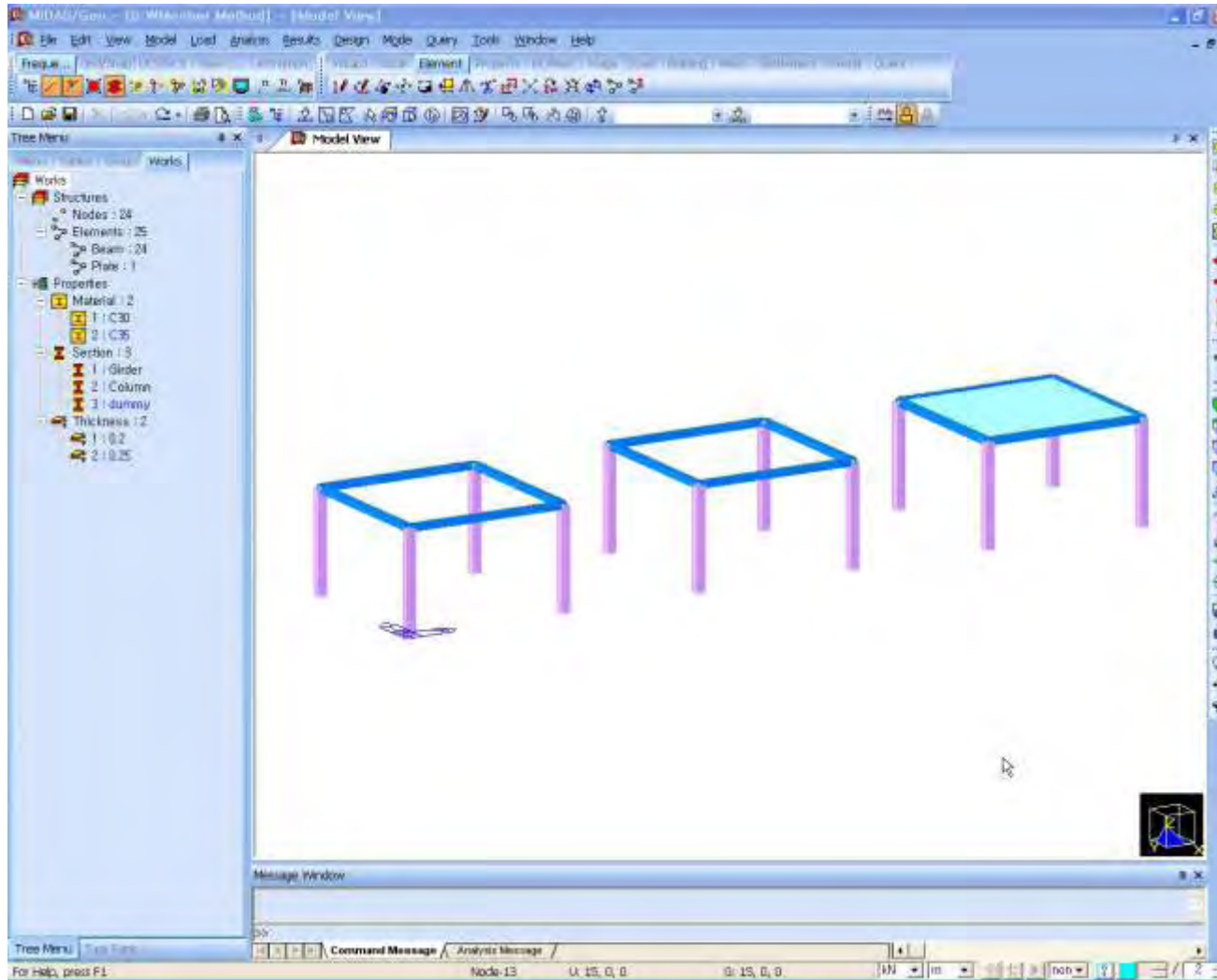

02 Main features and applications

Auto-mesh &
Slab/Wall Design

2.1 Auto-mesh main features

3. Mesh type

Quadrilateral

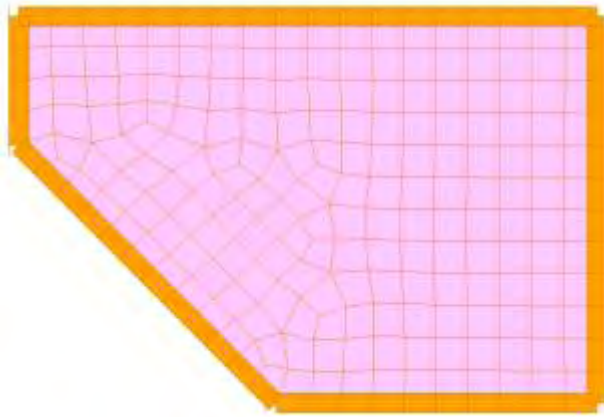

Quad+Triangle

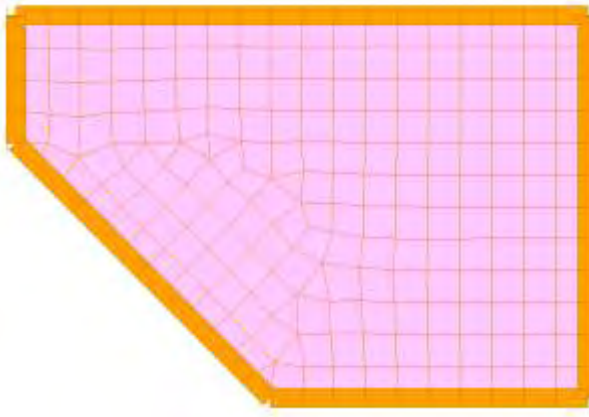

Triangle

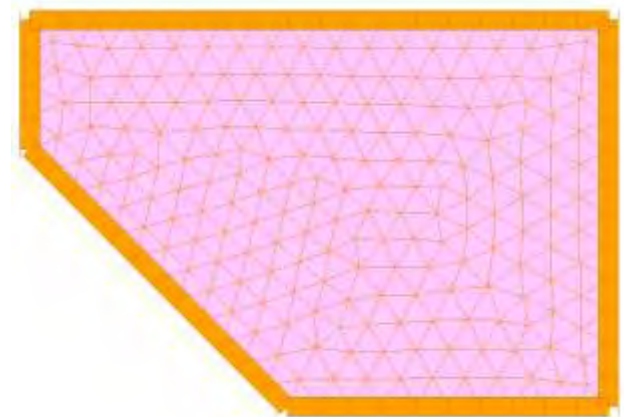

4. Mesh size

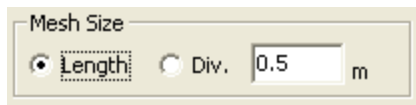

- **Length** : Specify mesh size as length
- **Division** : Specify the number of division

02 Main features and applications

Auto-mesh &
Slab/Wall Design

2.1 Auto-mesh main features

5. Auto-mesh considering interior nodes, lines and openings

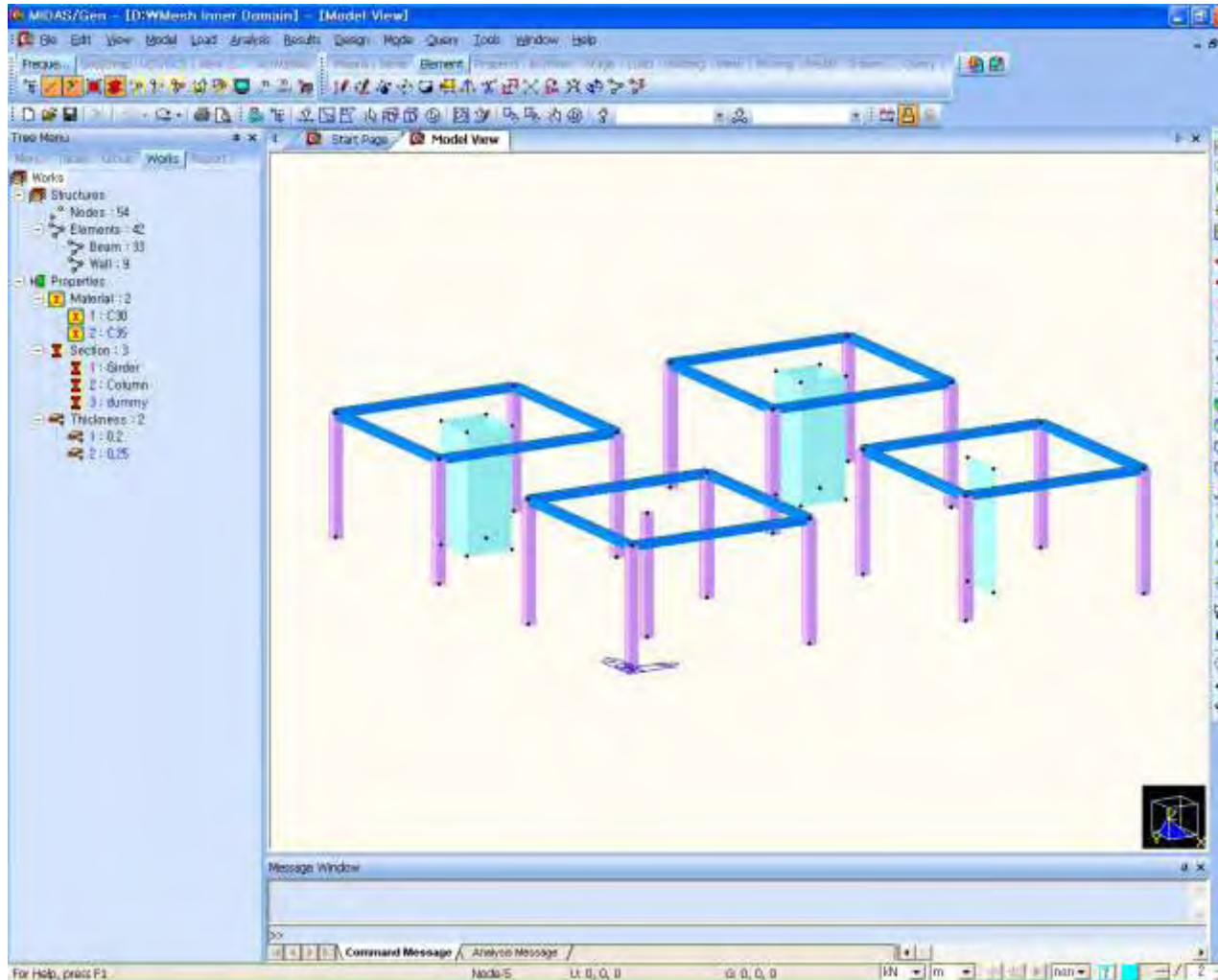

02 Main features and applications

Auto-mesh &
Slab/Wall Design

2.1 Auto-mesh main features

6. Opening

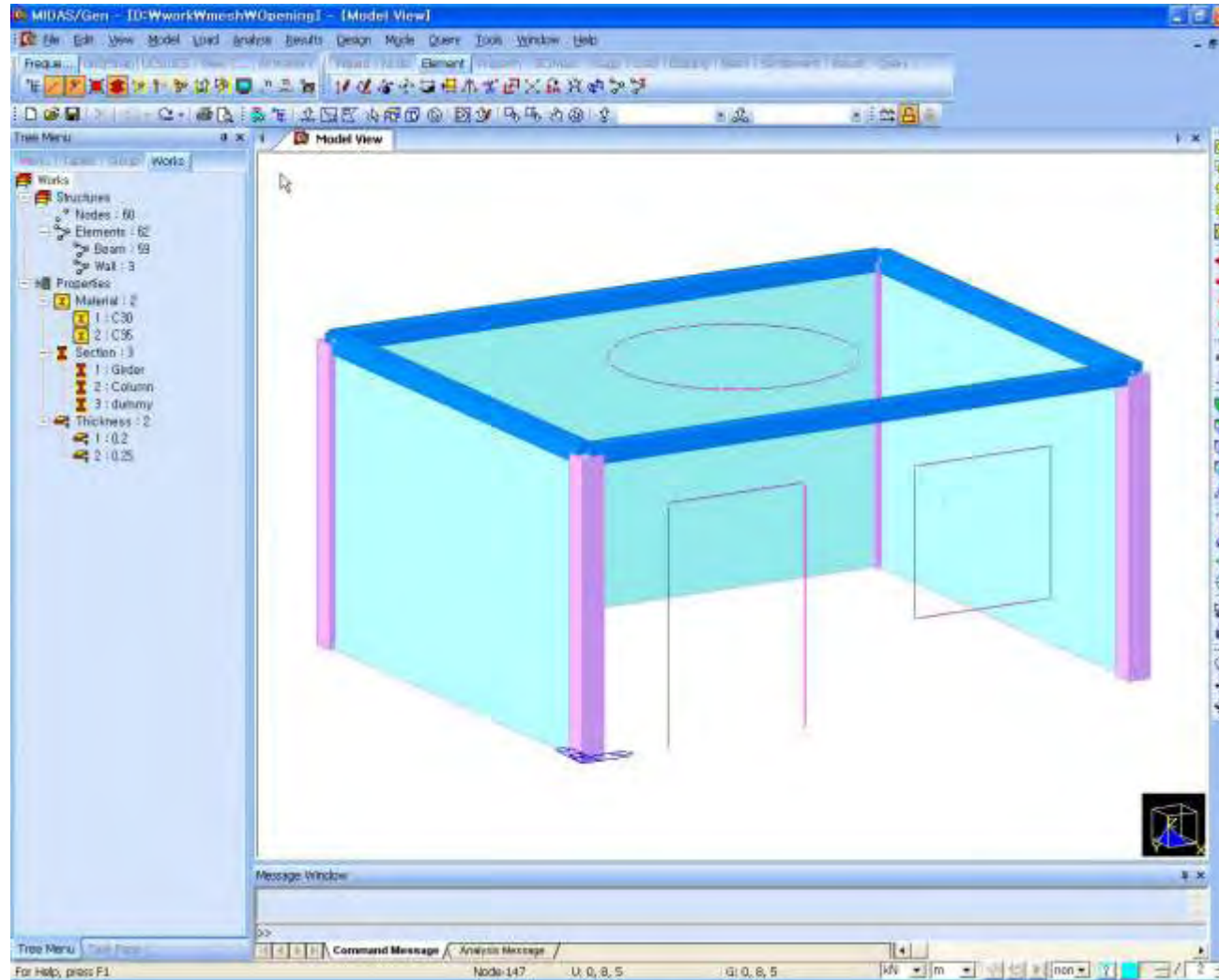

02 Main features and applications

Auto-mesh &
Slab/Wall Design

2.1 Auto-mesh main features

7. Connectivity between slab and wall

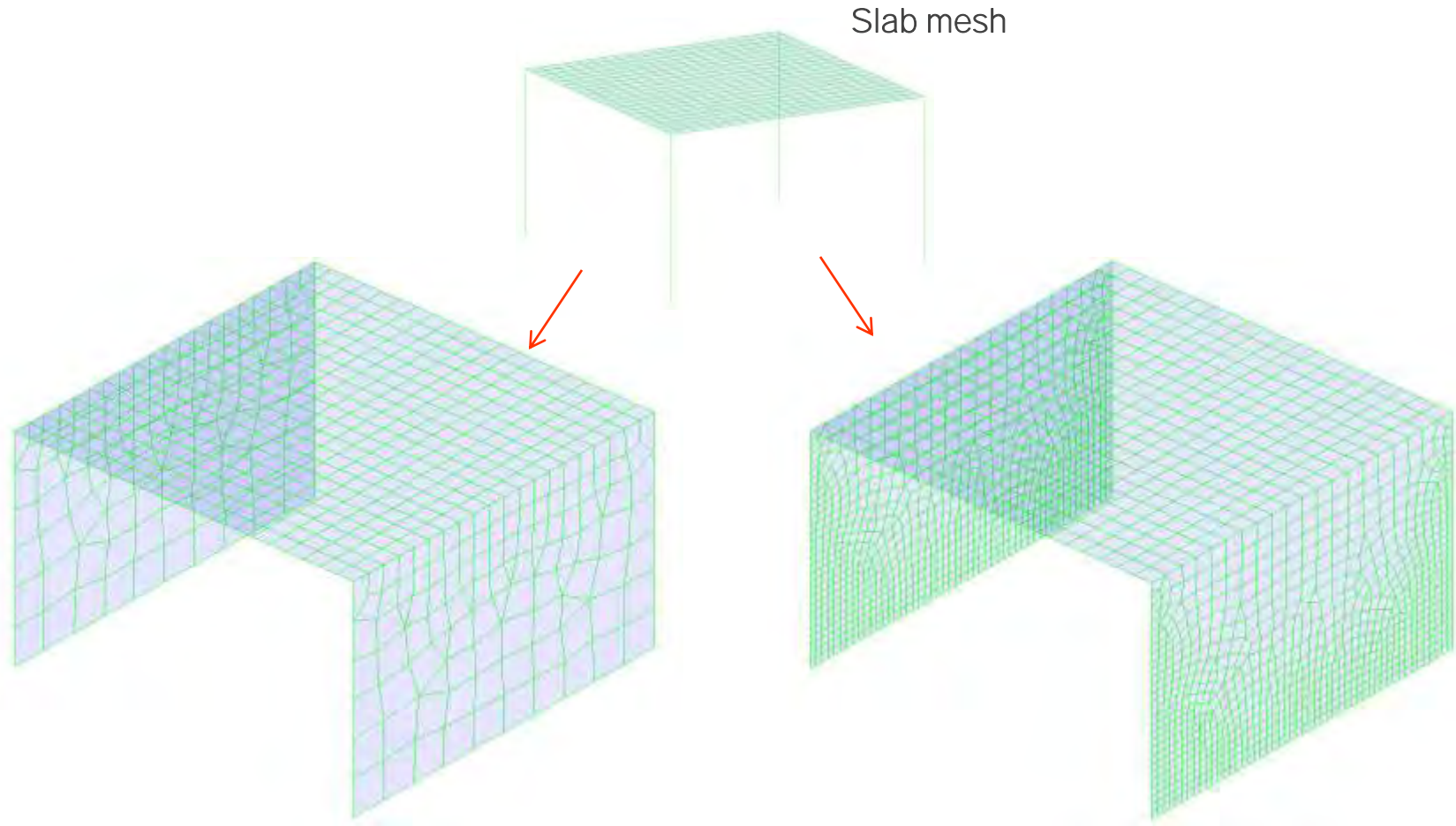

When wall mesh size is larger than slab mesh size

When wall mesh size is smaller than slab mesh size

02 Main features and applications

Auto-mesh &
Slab/Wall Design

2.1 Auto-mesh main features

8. Division of Boundary line elements and automatic member assignment

The diagram illustrates the process of dividing boundary line elements and assigning members. It shows a 3D model of a table frame (top) and the same model with a meshed slab on top (bottom). A yellow arrow points from the frame to the meshed slab. A red oval highlights the meshed slab, and a red arrow points from it to the 'Member Assignment' dialog box.

Member Assignment

Option
 Add/Replace Delete

Member
 Allow Single Element Member

Assign Type
 Manual Automatic

Selection Type
 All By Selection

Index	Element List
37	37, 684, 685, 686, 687, 688,
201	201, 707, 708, 709
202	202, 704, 705, 706
203	203, 693, 694, 695, 696, 697
236	236, 903, 904, 905, 906, 907
237	237, 710, 711, 712, 713, 714
239	239, 894, 895, 896, 897, 898
245	245, 927, 928, 929, 930, 931
247	247, 721, 722, 723, 724, 725
248	248, 912, 913, 914, 915, 916

02 Main features and applications

Auto-mesh &
Slab/Wall Design

2.1 Auto-mesh main features

9. Create boundary line elements by selecting mesh elements

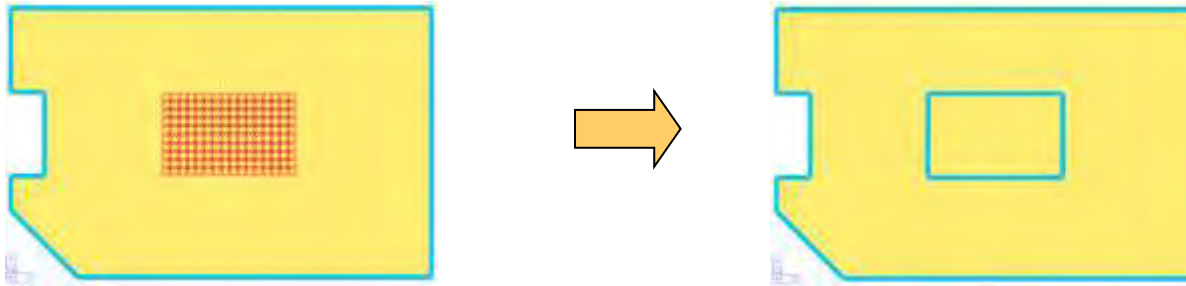

10. Redistribution of pressure loads

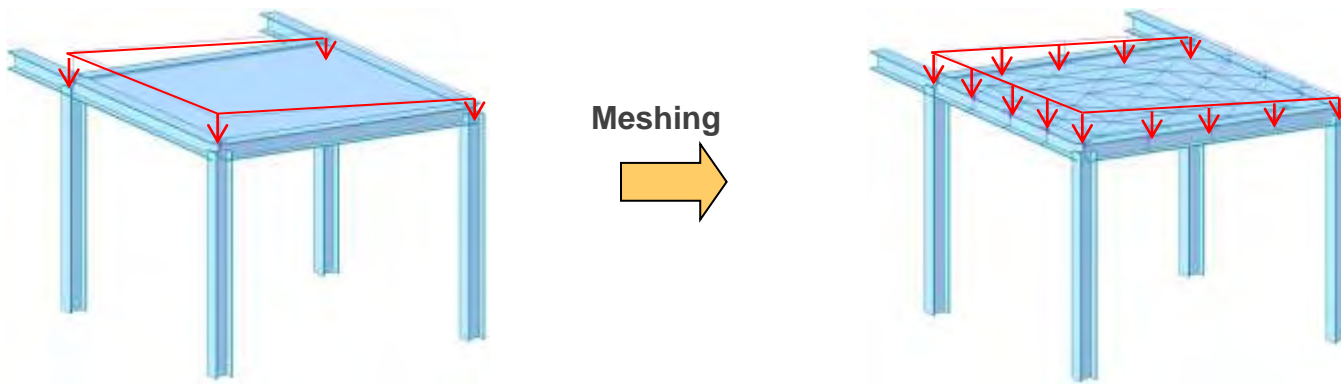

02 Main features and applications

Auto-mesh &
Slab/Wall Design

2.1 Auto-mesh main features

11. Map-mesh (variation of mesh size)

□ Bias Ratio

Ratio between first mesh size and last mesh size

Considering the variation of mesh size as well as identical mesh size

When Bias Ratio is 1,

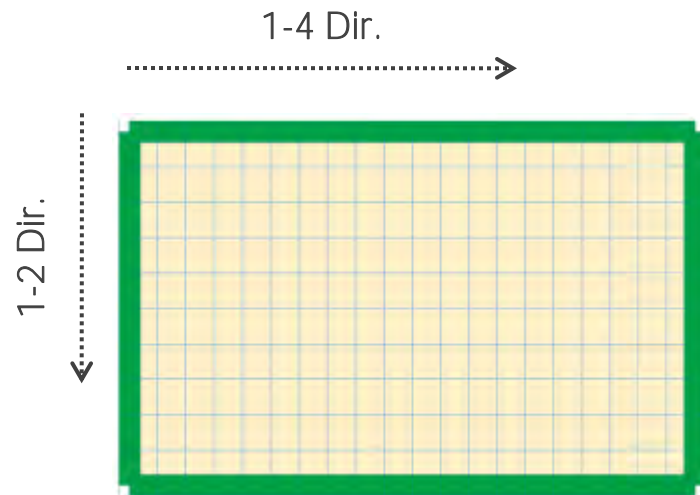

When Bias Ratio is 4,

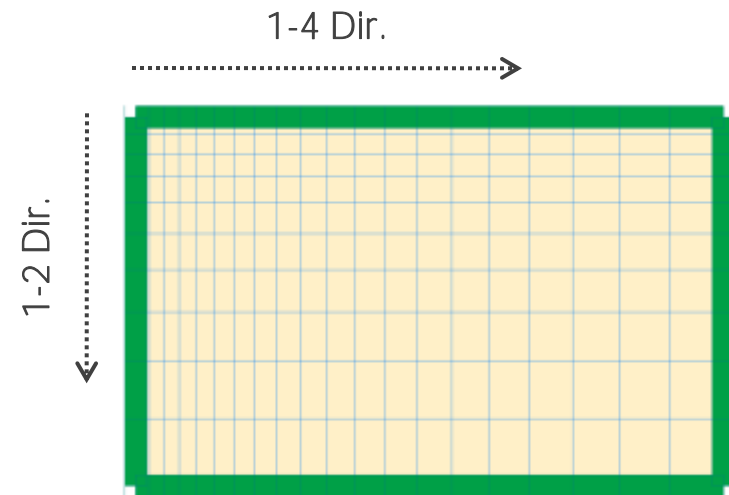

02 Main features and applications

Auto-mesh &
Slab/Wall Design

2.1 Auto-mesh main features

12. Domain and Sub-Domain

Domain: Assign element type, material and section property at once

Sub-domain: Unit of Slab/wall design

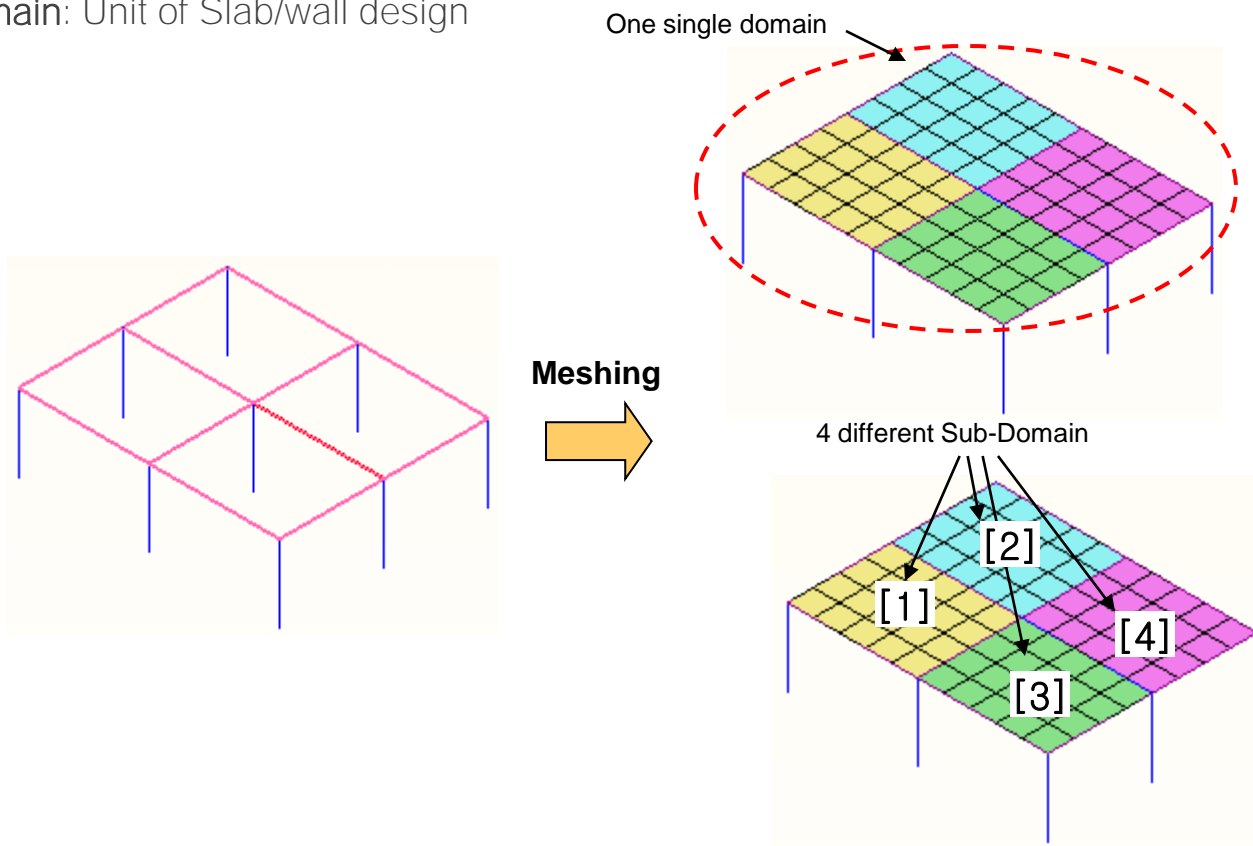

02 Main features and applications

Auto-mesh &
Slab/Wall Design

2.2 Applications

□ Demonstration

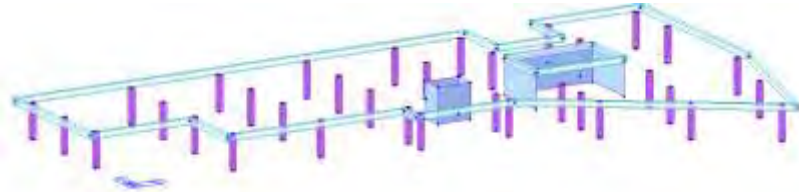

Slab Auto-mesh

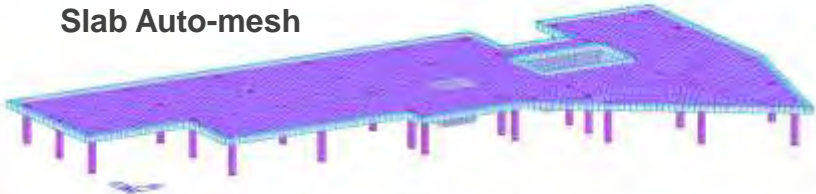

Building Generation

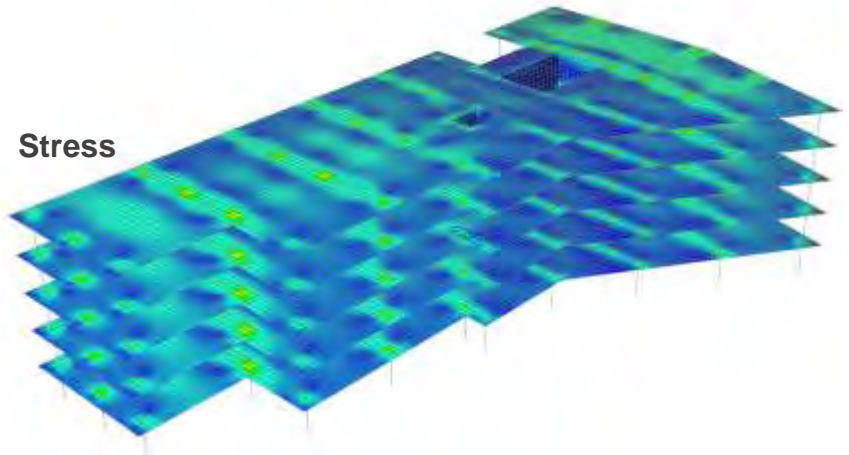
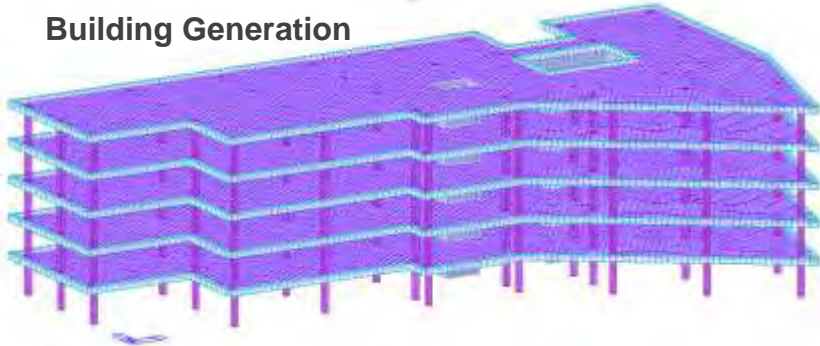

Stress

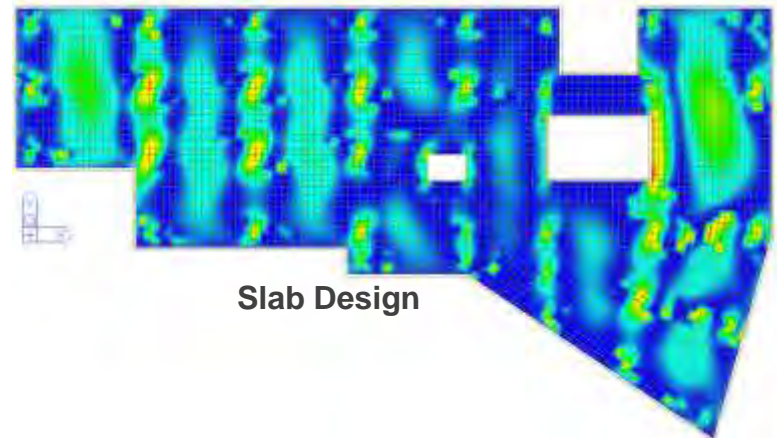

Slab Design

02 Main features and applications

Auto-mesh &
Slab/Wall Design

2.2 Applications

Shear wall and frame building

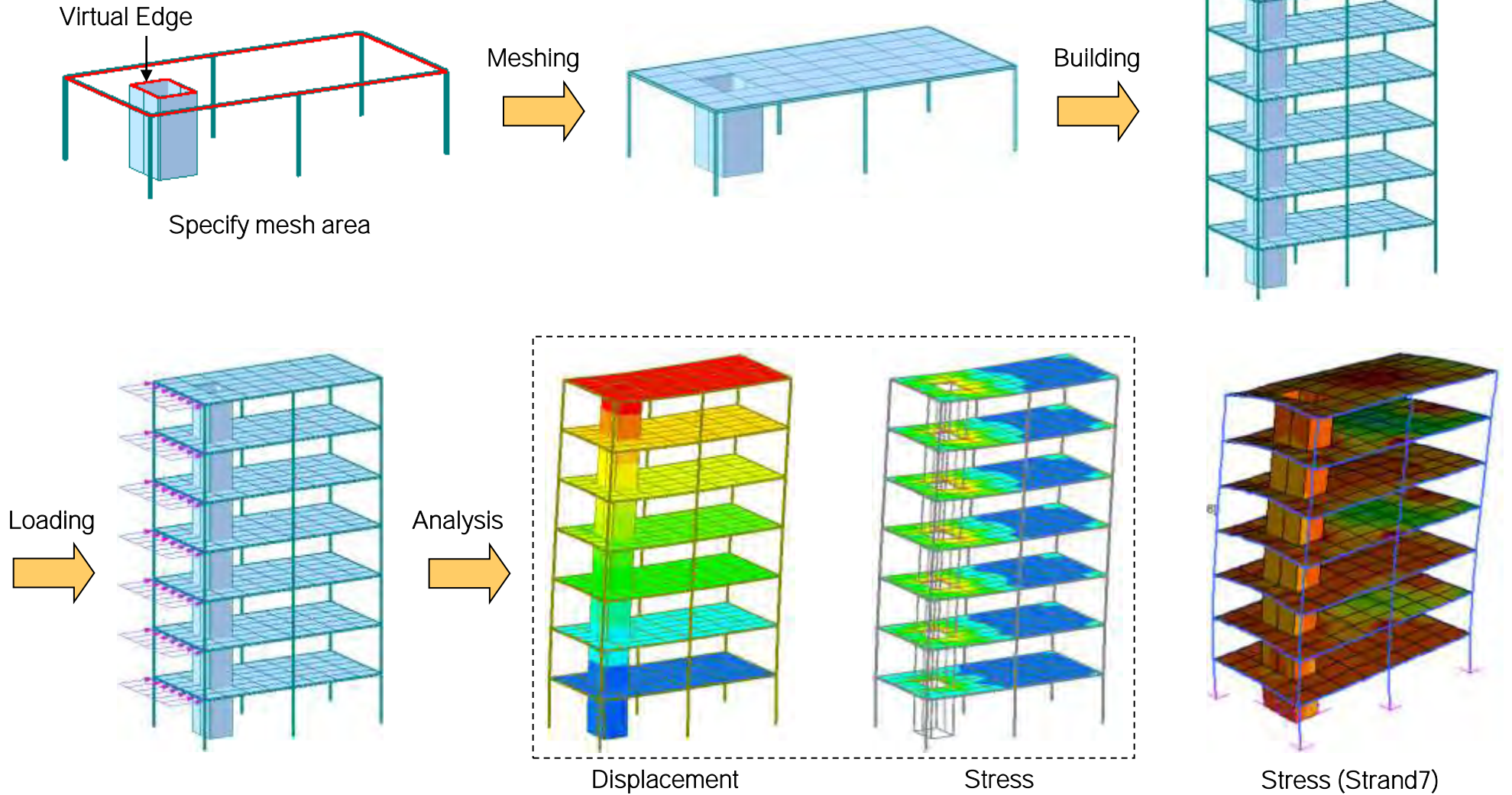

02 Main features and applications

Auto-mesh &
Slab/Wall Design

2.2 Applications

□ Bracket

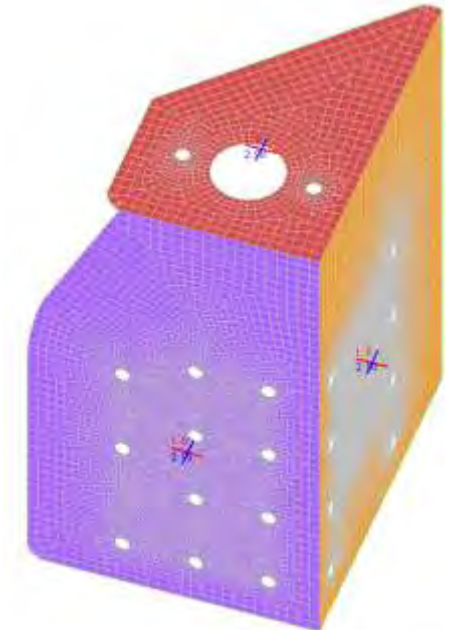
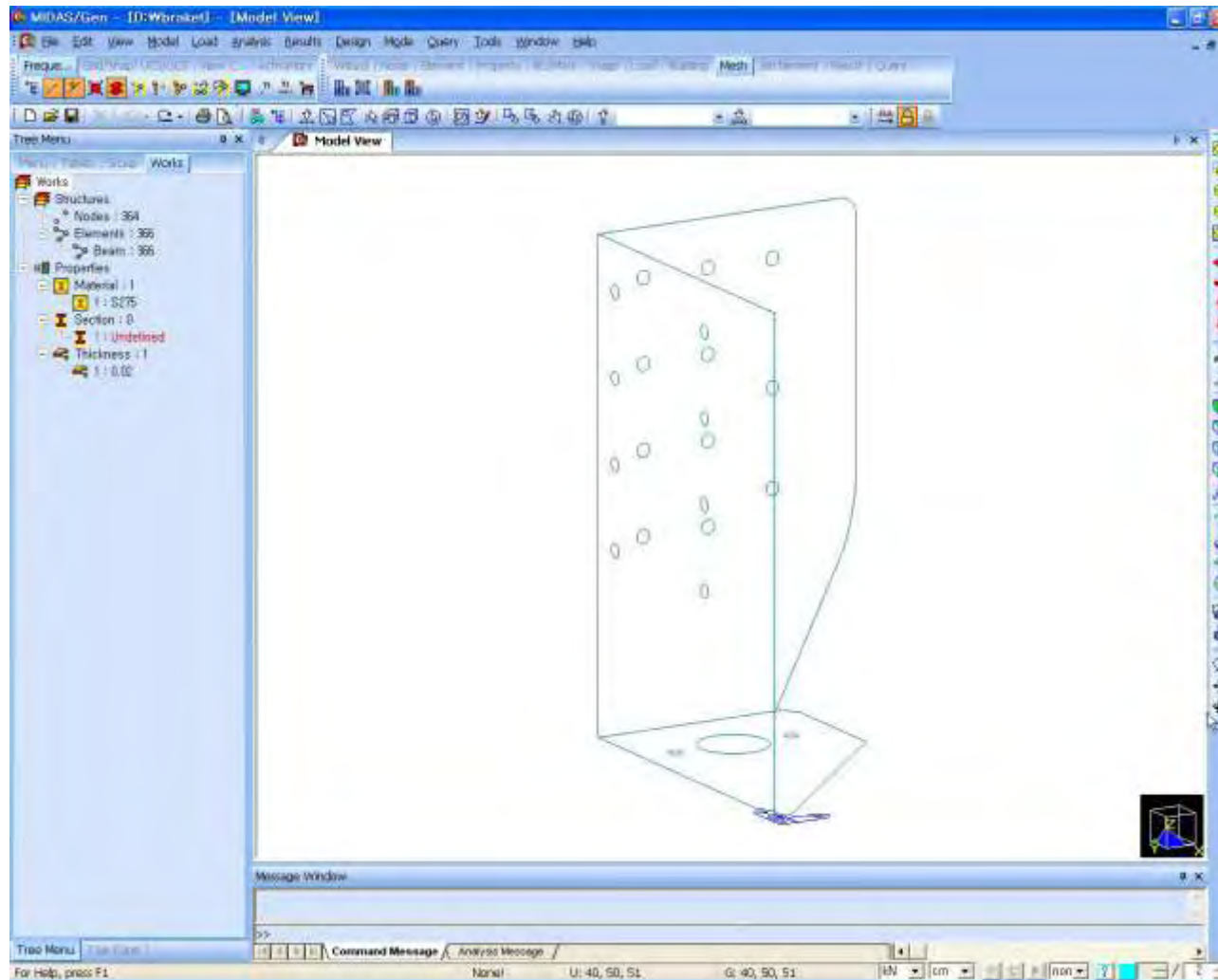

02 Main features and applications

Auto-mesh &
Slab/Wall Design

2.2 Applications

Arch-tube modeling

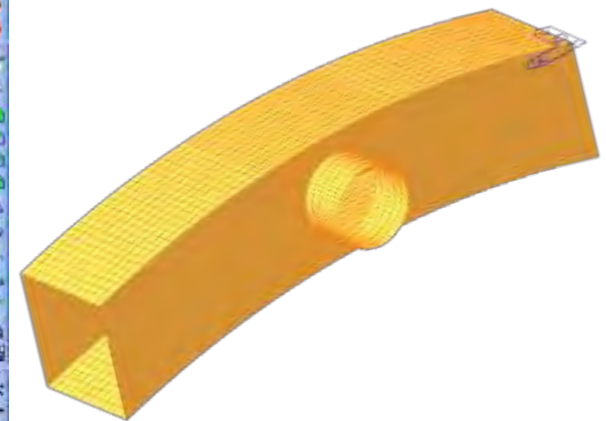
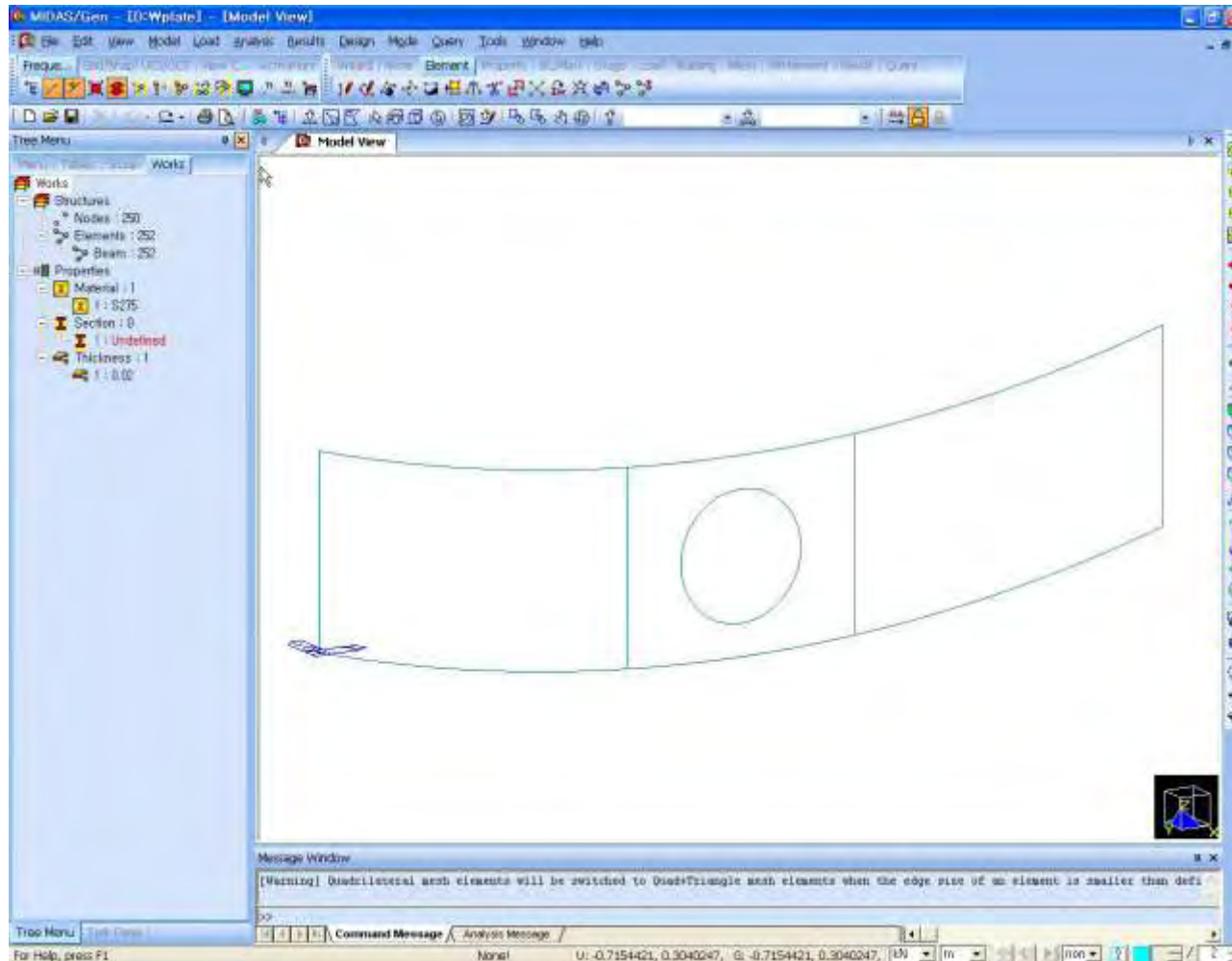

One part of Arch tube

02 Main features and applications

Auto-mesh &
Slab/Wall Design

2.2 Applications

□ Rahmen bridge

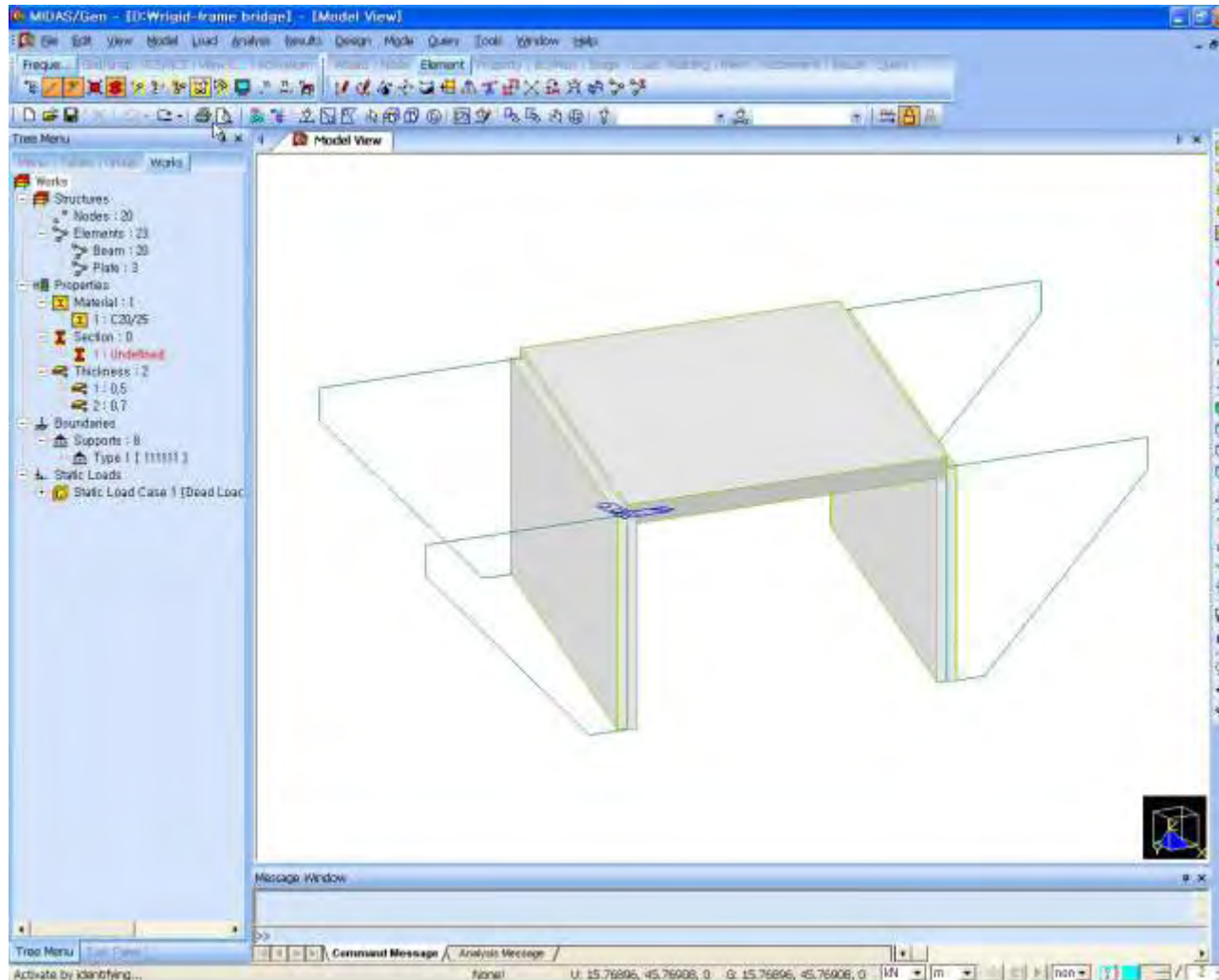

02 Main features and applications

Auto-mesh &
Slab/Wall Design

2.2 Applications

□ Subway station

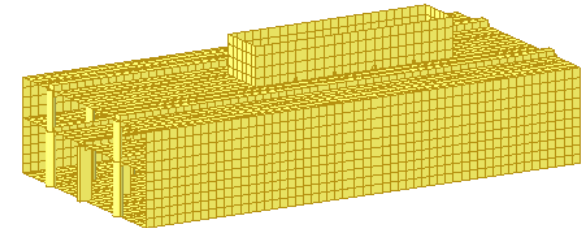
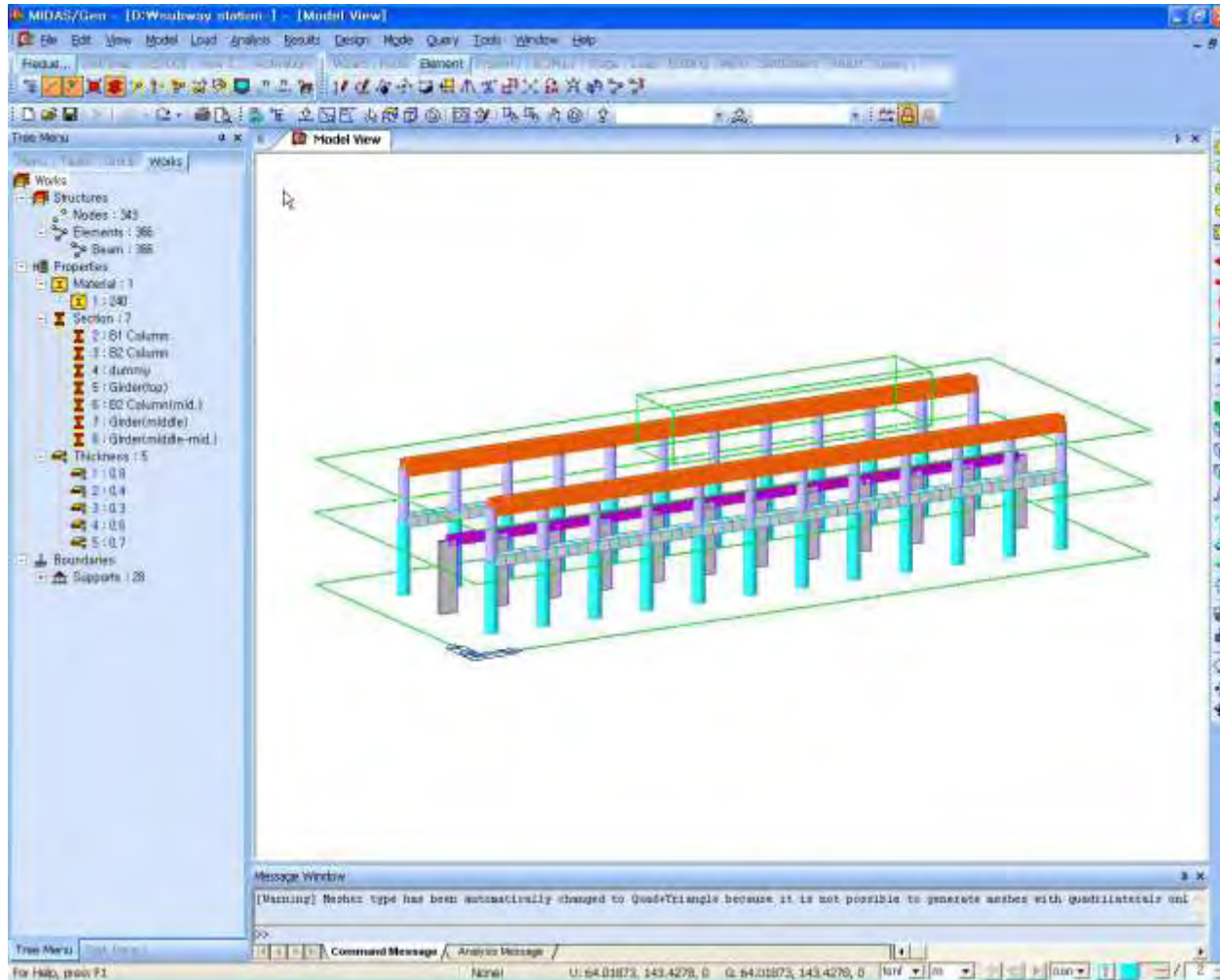

02 Main features and applications

Auto-mesh &
Slab/Wall Design

2.2 Applications

□ Plate Girder Bridge

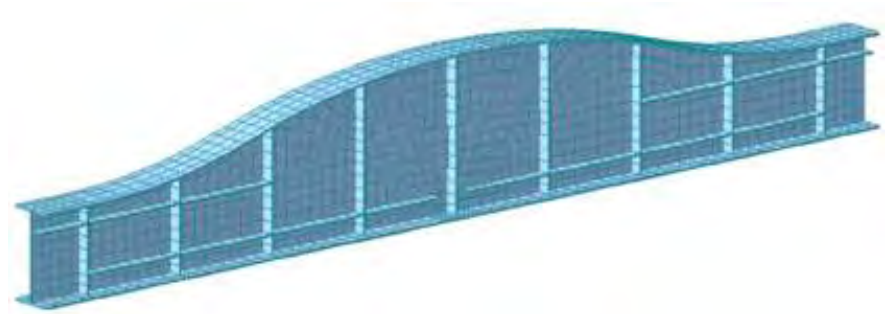
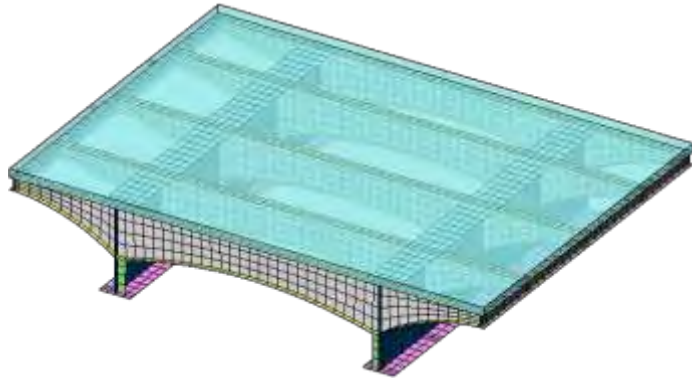

□ Pumping Plant

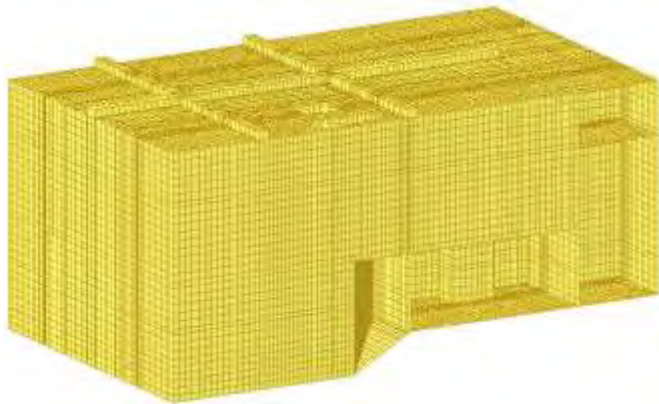

□ Caisson

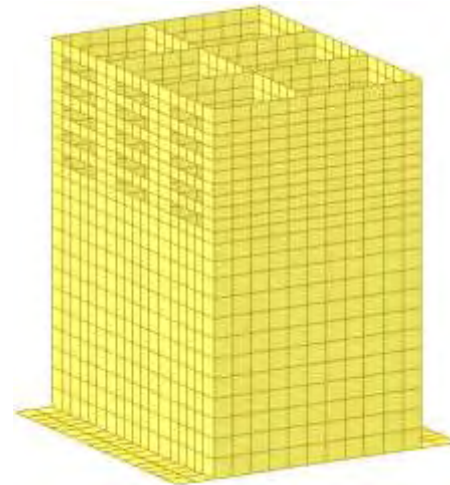

02 Main features and applications

Auto-mesh &
Slab/Wall Design

2.3 Slab/Wall Design main features

Slab/Wall Design

❑ Slab flexural Design/checking

- Slab design by Wood-Armer Moment method
- Check one-way flexural moment

❑ Slab Shear Checking

- Punching Shear Check, Required rebar area
- Check one-way shear force

❑ Slab Serviceability Checking

- stress checking (Concrete, Rebar)
- crack control (crack width, minimum rebar area, maximum bar spacing, maximum bar diameter)
- deflection (Un-cracked section, Considering long-term deflection due to creep)

❑ Meshed Wall Design/Checking

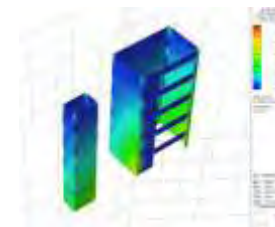
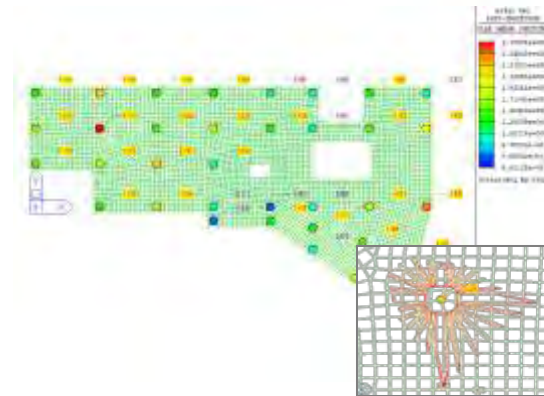
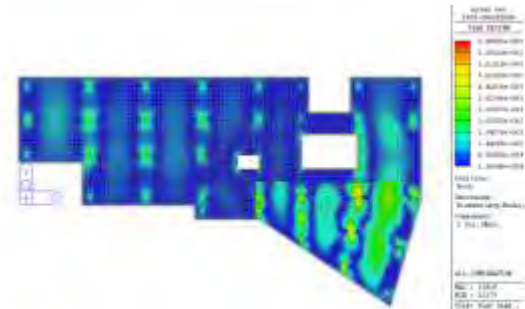

02 Main features and applications

Auto-mesh &
Slab/Wall Design

2.3 Slab/Wall Design main features

Sub-Domain

- Sub-Domain can be used as a unit of slab design.

Detail results will be provided for the most unfavorable results by sub-domains.

- Specifying direction of rebar in Slab
- Thickness for design

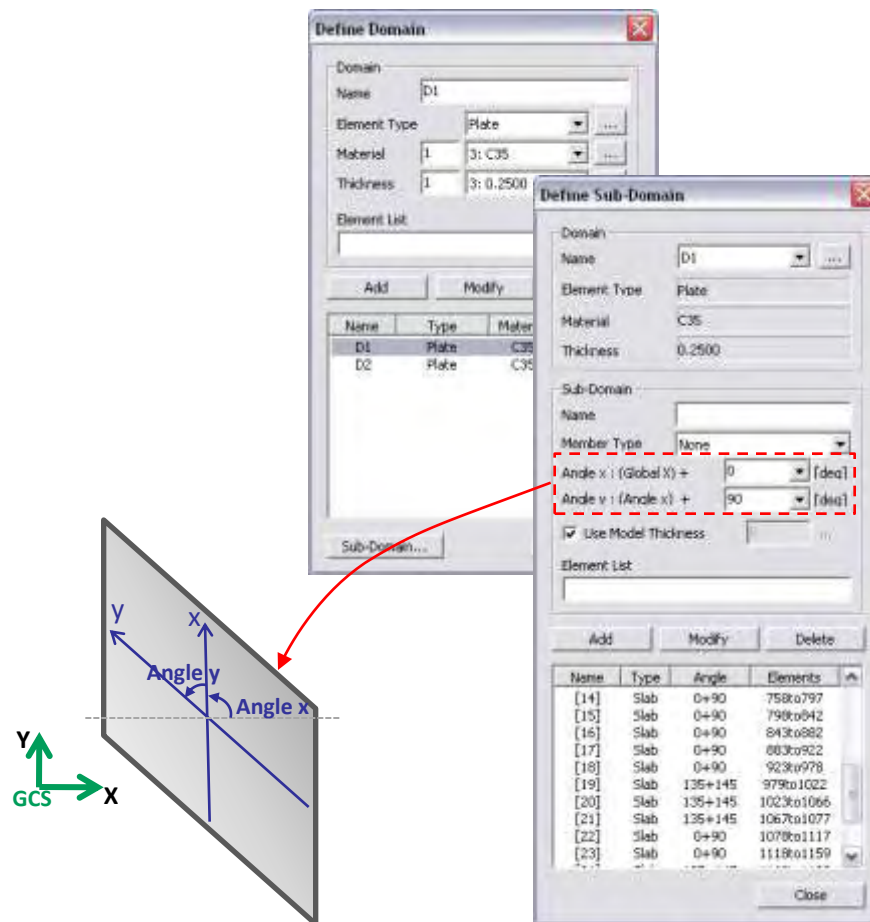
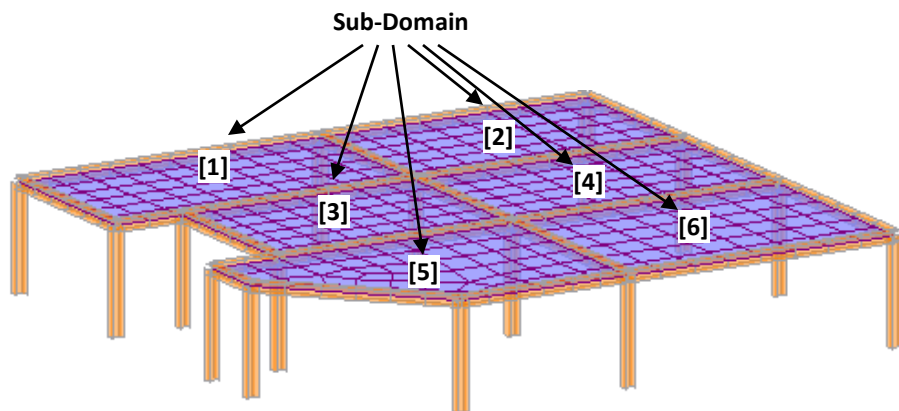

Rebar direction

Angle x: x-direction rebar from Global X-axis

Angle y: y-direction rebar from Angle x-axis

02 Main features and applications

Auto-mesh &
Slab/Wall Design

2.3 Slab/Wall Design main features

Static wind and seismic load for flexible floor

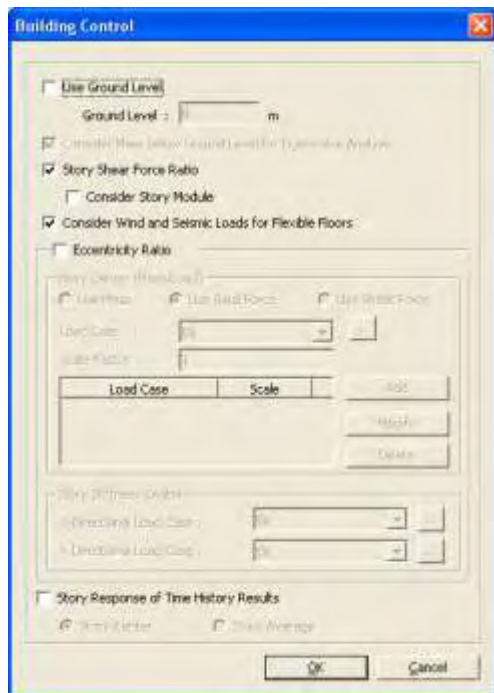

Wind Load

Concentrated Load

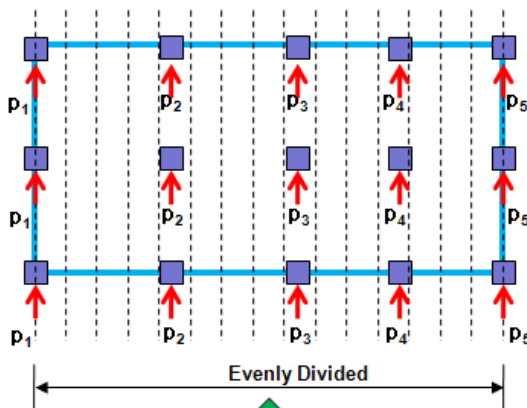

P

Seismic Load

Concentrated Load

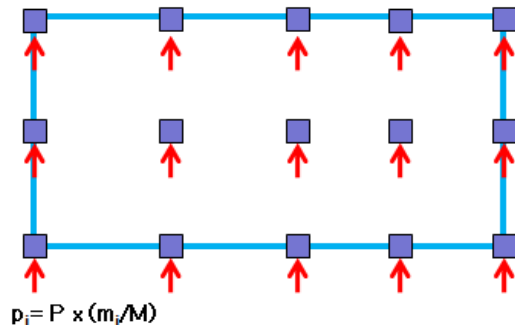

P

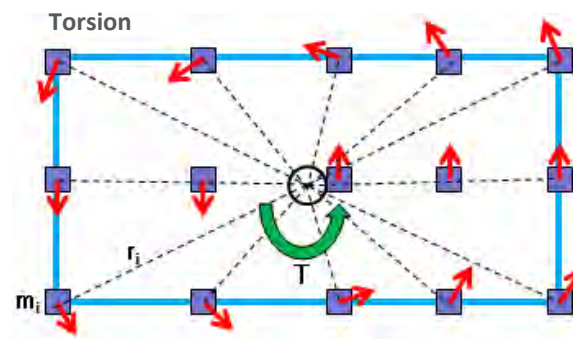

03 Demonstration

Auto-mesh &
Slab/Wall Design

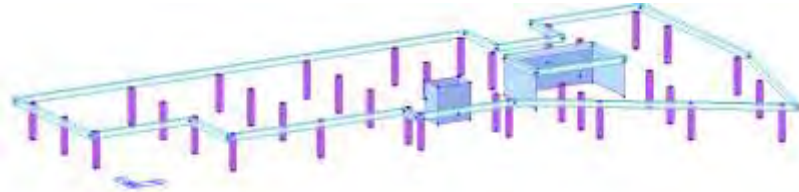

Slab Auto-mesh

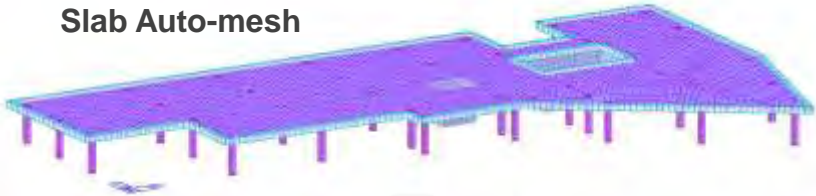

Building Generation

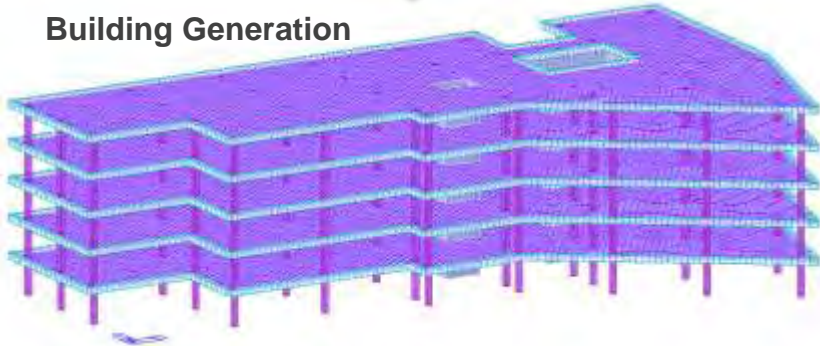

Displacement

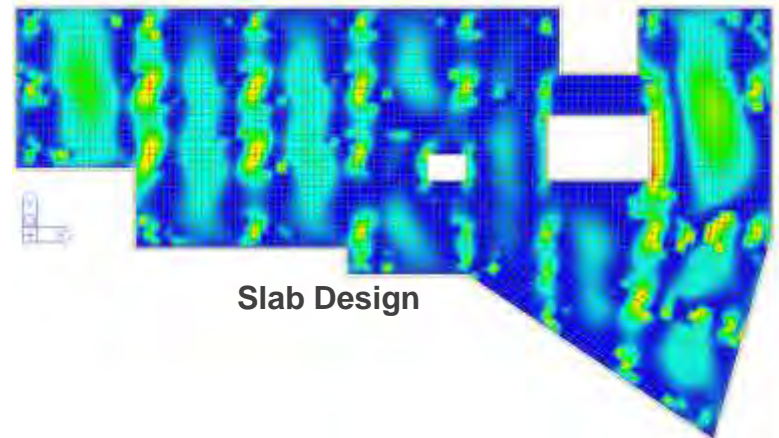
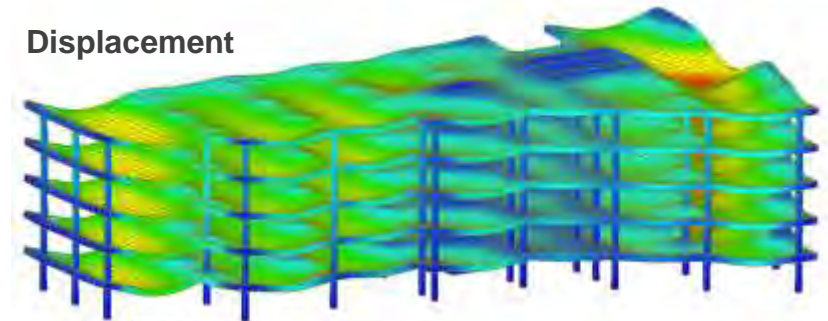

Slab Design

03 Demonstration

Auto-mesh &
Slab/Wall Design

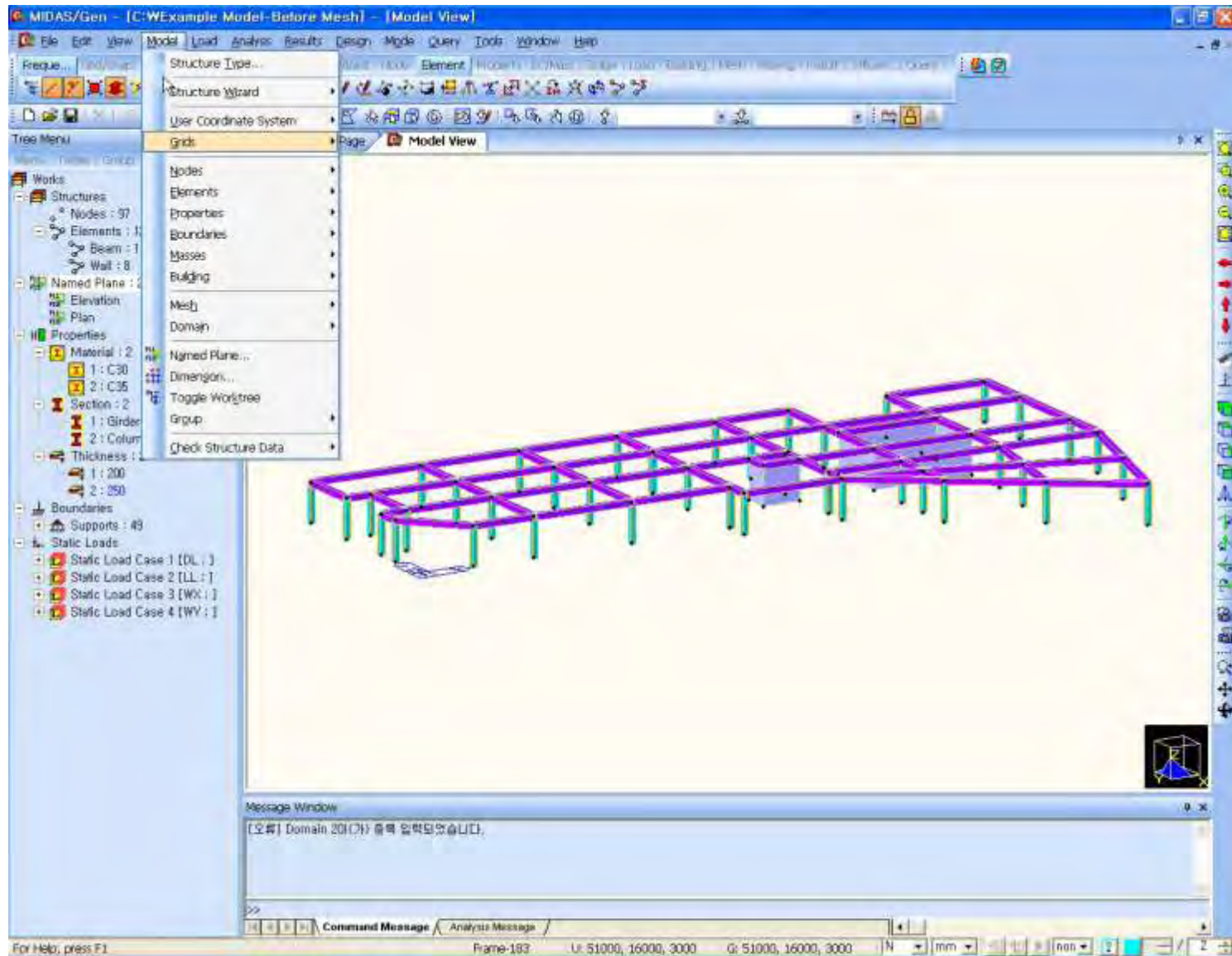

04 Further development

Auto-mesh &
Slab/Wall Design

❑ Further development plan

- Slab Serviceability Checking (Deflection for cracked section)

❑ Further consideration

- Improvements in opening for automesh
- Slab design considering in-plane forces
 - k-node map-mesh
 - Preview Seeding, Preview Meshing
 - local direction force sum for unconstructed meshes